

Adjustable Temperature Control Kit

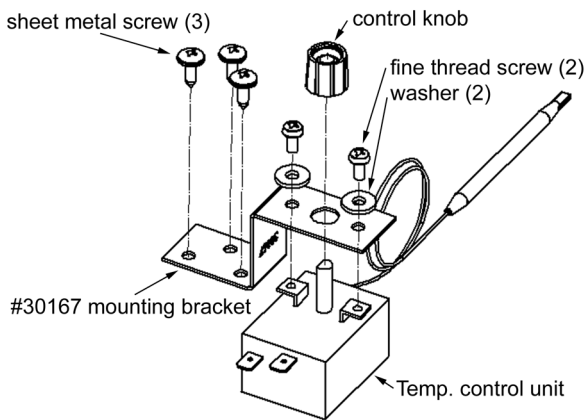

Insert the temp. sensor near the inlet hose...



Then push the insulator cap over the end of the sensor.

Assembly & Installation Instructions

1. Attach the temp. control unit to the mounting bracket using the hardware provided, then push the knob onto the control shaft.
2. The control can be mounted to any flat surface in the engine compartment that is within 18" of the radiator inlet hose. Use the 3 mounting screws provided.
3. Insert the temp. sensor thru the radiator core as close to the inlet hose as possible, then push the rubber insulator cap over the end of the sensor as shown.
4. Connect the "C" terminal on the control unit to the positive (+) lead on electric fan unit. For automatic operation, connect the "2" terminal on the control unit to a fused positive (+) source that is capable of powering the electric fan unit (refer to wiring diagram below). Use the female connectors provided.
5. If manual control is desired, use P/N 31148 / 31148N. Refer to wiring diagram below. **NOTE: If not using a Flex-a-lite manual switch, DO NOT connect the ground (-) wire to the switch!**

To Adjust Temperature Control

1. Turn the adjusting knob on the controller completely clockwise. Idle the vehicle.
2. When the engine temperature gets above normal, turn the adjusting knob counterclockwise until fan activates. Adjusting knob may be adjusted counter-clockwise to reduce the temperature at which fan activates.

Wiring Diagram

