

Introduction

Thank you for your purchase of the Auto Meter NEXUS instrument system. Built with N2.0 technology, the NEXUS system is able to be installed and expanded efficiently with simple modular network cables. Gauge features are operated by remote control for a clean appearing dial face and optimized user control. NEXUS instruments feature the aesthetic good looks of a tinted lens and polished bezel, with the easy readability of a glowing red pointer and user-selectable high contrast LED lighting. Initialization, Shutdown, Demo, and Color sequencing displays combine with full dial warnings, peak recall, run recording, playback, and data analysis for the ultimate combination of street and performance features. Please read the following instructions carefully and completely before installing or operating your NEXUS system to ensure proper operation and warranty compliance.

Content

- Introduction 1
- Parts List 3
- Installation4-7
 - a. Mounting 4
 - b. Remote Control 4
 - c. Wiring 5
 - d. Optional Tachometer Wiring 6
 - e. Gauge Network Connections 7
 - f. Sensor Connections to Module 7
 - g. Harness Connections 7
- Operation8-10
 - a. Initialization Sequence 8
 - b. Shutdown Sequence 8
 - c. Demo Operation 8
 - d. Illumination 9
 - i. Color 9
 - ii. Dynamic Color Sequence Light Display 9
 - iii. Dimming 9
 - e. Warning Point Set and Operation 10
 - f. Peak 10
 - g. Record 10
 - h. Playback 11
- SD Card Expansion 11
- FAQ/Troubleshooting 12
- Customizing NEXUS 12
- Notes13-15

Parts List:

a. Sensor module

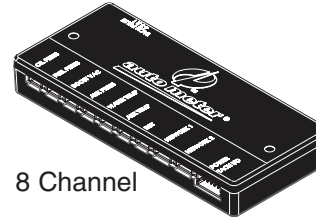

8 Channel

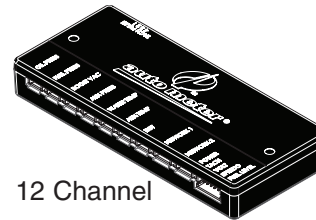

12 Channel

c. Power harness

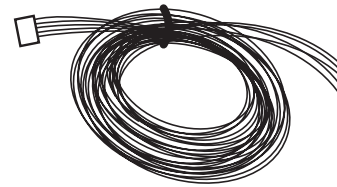

e. Velcro sheet

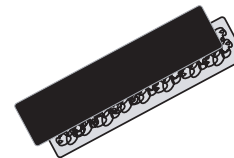

g. Self-Tapping Screws (2)

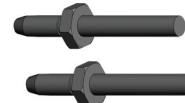

b. Remote and six foot cable



d. Six foot Network Cable

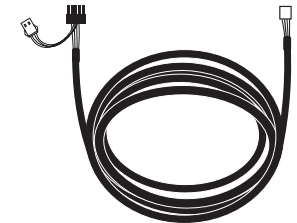

f. Software Demo CD

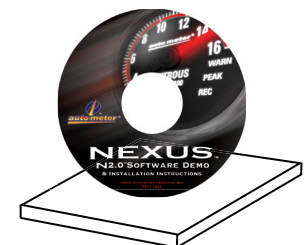

h. Thumb Nuts (2)

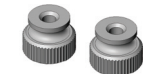

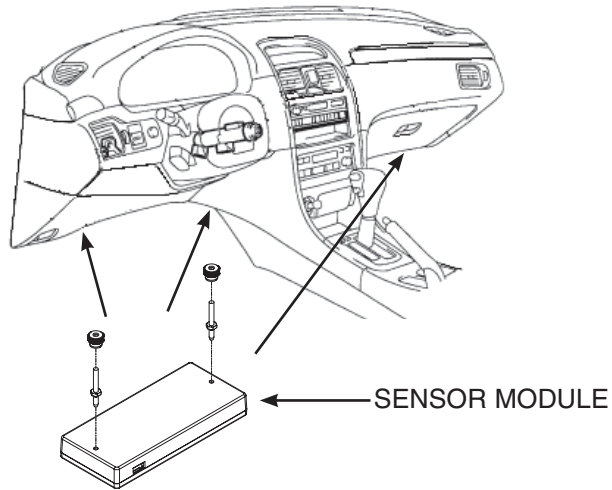

Installation:

a. Mounting:

- i. **Note:** Disconnect negative battery cable and make sure engine and exhaust have been allowed to cool before proceeding with installation.
- ii. Locate suitable location for mounting of sensor module for your Nexus system. Recommended locations are under-dashboard, in kick panel, behind or under center console, or other suitable location.

Do NOT mount sensor module in engine compartment. Product is intended for interior mounting only and is not protected against high temperatures and moisture that may be present outside of vehicle interior.

Do NOT mount sensor module or remote in close proximity to ignition coils or ignition spark boxes as they often produce electrical signals that can interfere with and/or damage your Nexus system. **Failure to comply with this mounting procedure will void your warranty and may result in damage to and failure of your Nexus instrument system.**

- iii. To mount your sensor module and remote, velcro and screws are supplied. Locate sensor module mounting location, mark holes from case on mounting surface and drill and mount with screws and nuts. Clean mounting surfaces for remote with a damp cloth to ensure proper adhesion. Peel backing off of glue strips and mount Velcro halves. Press product into place.

Note: Clean interior mounting surface thoroughly of cleaners and protectants before applying Velcro for best adhesion.

b. Remote Control:

- i. Test fit for suitable remote location and cable length to sensor module. Route cable as necessary. To ensure proper operation, ensure cable is not pinched and will not rub and wear through insulation resulting in system malfunction and damage to your Nexus system.
- ii. Plug remote cable into a network port on the sensor module or into a gauge network. Loosely coil and zip tie excess remote cable.
Do not lengthen or shorten cable length.

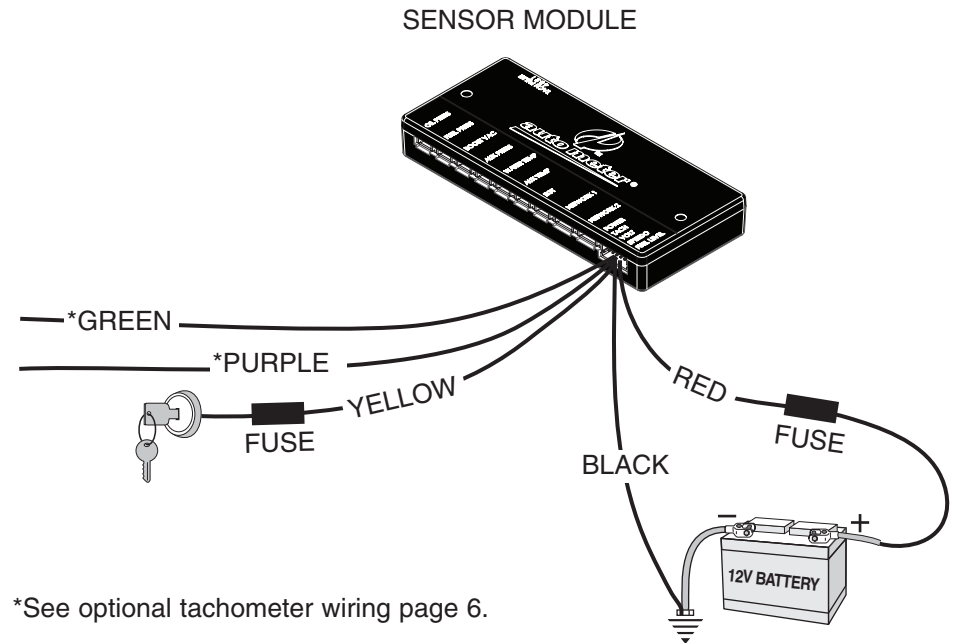

*See optional tachometer wiring page 6.

c. Wiring:

1. **Black Wire:** Connect black wire from power harness to battery negative or other good ground source such as engine, chassis, or fuse box grounds. Failure to obtain sufficient ground connection will cause improper operation of your Nexus system.
2. **Red Wire:** Connect red wire from power harness to constant +12v source. Place a 3 amp automotive fuse (available commercially) in line with this connection to protect your NEXUS system. Must stay powered during engine startup and while ignition switch is off.
3. **Yellow Wire:** Connect Yellow wire from power harness to switched +12v source. Place a 1/2 amp automotive fuse (available commercially) in line with this connection to protect your NEXUS system. Must stay powered during engine start and crank but turn off when ignition switch is off.

Note: Additional wires included in harness not mentioned in this instruction are for gauge specific hookup and not required specifically for module installation. Please see specific gauge instructions for more information about these wires.

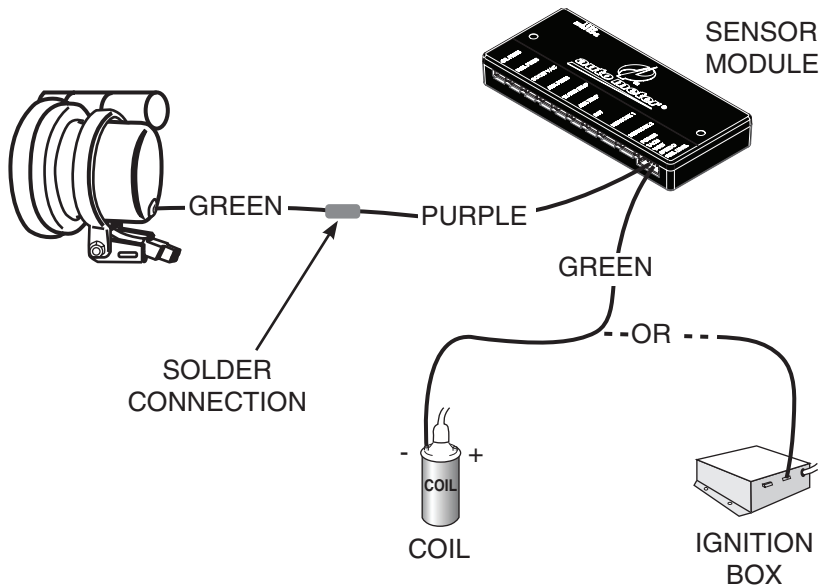

d. Optional Tachometer Wiring:

1. **Green Wire:** Connect green wire from power harness to engine RPM signal, such as computer tach signal or coil negative, if tachometer is also installed with NEXUS system. On newer vehicles with multi-coil ignition systems, DIS tach adapter #9117 may be required for proper operation.
2. **Purple Wire:** Connect purple wire from power harness to signal input wire (green) on Auto Meter tachometer.
3. **Select Cylinder Setting or Pulses Per Revolution:** Flip appropriate pulse selector switch up towards the top of the case on the NEXUS sensor module to activate the appropriate setting. See illustration below.

- a. $\frac{1}{2}$ pulse for most 1 cylinder ignitions = All switches up.
- b. 1 pulse for most 2 cylinder and twin coil 4 cylinder ignitions = 1 pulse switch up.
- c. 2 pulse for most single coil 4 cylinder ignitions = 2 pulse switch up.
- d. 3 pulse for most single coil 6 cylinder ignitions = 3 pulse switch up.
- e. 4 pulse for most single coil 8 cylinder ignitions = 4 pulse switch up.

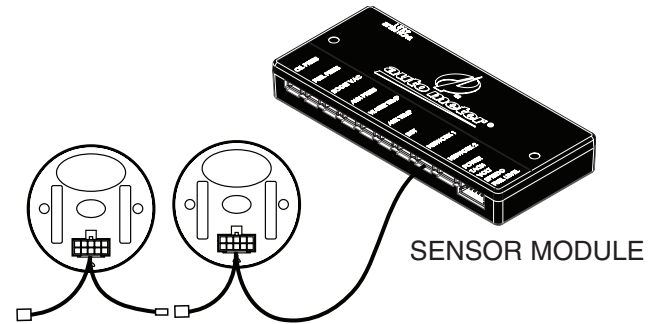
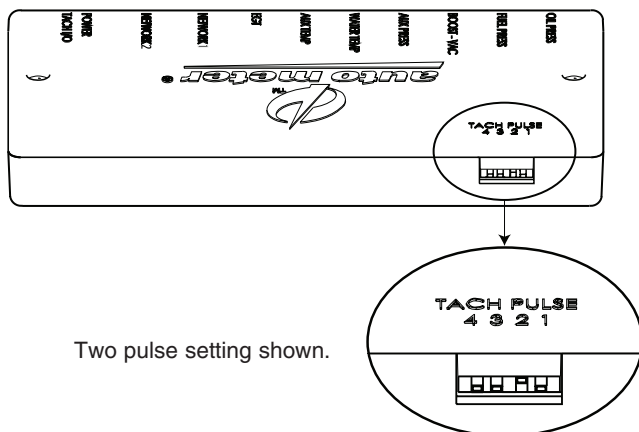

e. Gauge Network Connections:

Connect network cable to the first gauge in the series. See gauge instructions for further information. Use supplied network cables (included with gauge) to attach additional gauges to the network. Connectors will snap fit; do not apply excessive force to connection as damage to the system may result. Remote control will cycle through gauges in the order that the sensors are listed on the sensor module. In order to be able to cycle through the gauges in order across your dash, it will be necessary to connect and mount gauges in this arrangement. The NEXUS network will operate with any combination of Nexus instruments installed in any order, but remote cycle process will still follow the order of the sensor listings on the sensor module. Additional network cables of different lengths are available separately from Auto Meter.

f. Sensor Connections to Module:

See the table below for which ports the sensor harnesses plug into the Module.

Sensor Type	Module Connection Port
Oil Pressure	Oil Press
Fuel Pressure	Fuel Press
Vacuum / Boost Pressure	Boost – Vac
Oil OR Trans. Temperature	Aux Temp
Water Temperature	Water Temp
Nitrous pressure	Aux Press
Exhaust Gas Temperature	EGT

g. Harness Connections:

Connect all sensor harnesses to marked location on sensor module. When all sensor harnesses are connected, restore battery connections and turn ignition key to accessory position for activation. If wiring is correct, gauges should default to factory programmed initialization sequence. If initialization sequence does not occur, all gauges connected do not perform ceremony, or you have a blinking red MIL (malfunction indicator lamp) on the remote, check wiring connections and see the "Troubleshooting" section of this manual.

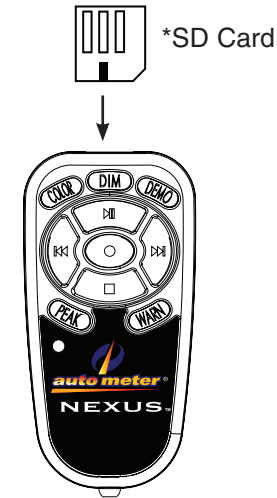
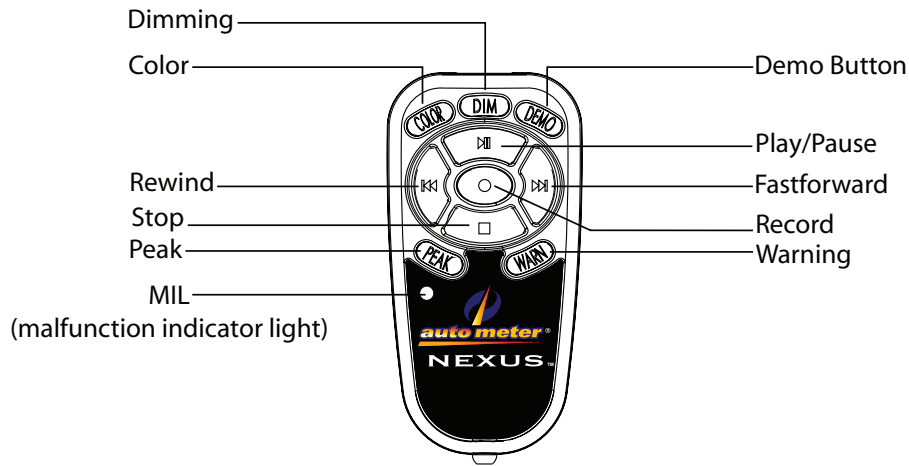

Operation:

a. Initialization Sequence:

When power is switched on to the NEXUS system, the gauges will auto calibrate, and then perform a factory programmed initialization sequence. Factory preset is as follows, pointers zero, then sweep to full scale and back to zero while changing colors and blinking the peak, warn, and record lights. When this sequence completes, the gauges will default to the last selected illumination color (factory preset will be blue) and pointers will indicate current readings supplied by appropriate sensors on the network.

b. Shutdown Sequence:

When the power is switched off to your vehicle, the NEXUS gauges will perform a factory programmed shutdown sequence. Factory preset is sweeping the pointers to max scale and back to zero while changing colors, and then fading to black.

c. Demo Operation:

Demo operation causes the gauges to sweep their pointers and blink lights, giving the appearance of motion and interest to your vehicle's interior. The Demo function of the NEXUS system can be engaged when the power is switched on to the system. By pressing the Demo button on the remote, the demo function will activate, causing the gauges to continuously play through the demo mode until the Demo button on the remote is pressed again which will end demo operation.

To create your own initialization, shutdown, and demo sequences, see the Customizing Nexus section.

d. Illumination:

- i. **Color:** The NEXUS system is constantly lit while operating. By pressing the Color button on the remote while the system is powered up, you can cycle through seven selectable illumination colors: red, white, blue, green, orange, purple, and yellow.
- ii. **Dynamic Color Sequencing Light Display:** NEXUS features a color sequencing display option that can be engaged by pressing and holding the Color button on the remote for 2 seconds. Once in color sequencing mode, the lighting of the NEXUS instruments will slowly shift through the seven illumination colors until the color sequencing mode is disabled by pressing the Color button on the remote.
Note: Record, Peak, Warn, and Dimming functions are disabled while in Dynamic Color Sequencing display mode.
- iii. **Dimming:** Hi-intensity LED illumination brightness for the NEXUS system can be adjusted via the system remote control, separately from your vehicle's interior dimming switch. Press the Dim button on the remote to cycle through five levels of illumination brightness.

e. Warning Point Set and Operation:

NEXUS is the first instrument system to feature a full dial warning alert. When a pre-programmed set point on the gauge has been reached, the gauge will change to red illumination to indicate that a warning condition has been reached (if default illumination is red, then warning light color will be blue).

Note: "Overwarn" feature - If the reading on the gauge extends 10% past the set point, then the gauge will begin to flash the warning color on and off. (The fuel level gauge will not do overwarn.)

To set a warn point, press the warn button on the remote. The warn light on the gauge to be set will turn on and the pointer will move to the current warning set point. Use the fast forward and reverse buttons on the remote to adjust the pointer position to the desired warning point (oil and fuel pressure gauge warnings activate when readings reach or drop below the set point all other gauge warnings activate when readings reach or rise above the set point).

Note: For 12 channel only: Fuel and Voltmeter warnings are also activated when readings drop below set warn point.

To cycle to the next gauge in the series, press the Warn button again. Repeat above process. Once you have set your desired set points, make no button presses on the remote for 2 seconds and NEXUS will store your new settings.

Note: Oil and Fuel Pressure gauges may indicate a warning condition before the vehicle is started. This is normal, starting the vehicle should raise pressures and shut warnings off. If warnings persist, shut off engine, check gauge warning points, and check vehicle fluid levels.

f. Peak:

Press the Peak button on the remote to view peak readings for all gauges on the network. All gauges will have the Peak light lit to indicate that they are showing peak readings. Press the Peak button again to cycle through each gauge reading individually. The gauge currently in peak mode will have its Peak light turned on. To leave Peak mode, make no button presses for 2 seconds for system to time out and return to normal operation. Clear your peaks by pressing the Stop button while in peak mode. If you press the Stop button while displaying all peaks, then all will be cleared. You may also cycle through and clear individual peaks by displaying the peak that you would like to clear and pressing the Stop button.

Note: For 12 channel only: The speedometer does not have the peak features.

g. Record:

To record continuous data, press the Record button on the remote. Nexus will record up to 30 sec. of continuous information from all gauges on the network including a tachometer for playback and data analysis from the time the Record button is pushed. The green Record lights in all gauges in the network will turn on to indicate recording is in process. When maximum record time has been reached the green Record lights will shut off, indicating record mode is no longer operating.

Note: You may extend record time by purchasing an SD card and inserting it into the SD card slot on top of the remote. See SD card expansion.

h. Playback:

Press the Play/Pause button on the remote and NEXUS will play back the recorded information in 1/3 time. The green Record lights on the gauges will flash and the MIL on the remote will come on and stay lit green to indicate that you have entered playback mode. You may press the Play/Pause button again to pause the gauges during playback. Use the Stop button to end playback and return to the beginning of the recording. Press and hold the Fast Forward and Rewind buttons to move forwards and backwards through the recording in real time. Releasing these buttons will pause the playback operation. To exit playback mode, press the Stop Button. **Current recorded (saved) information will be recorded over the next time you enter record mode.**

SD Card Expansion:

- a. **Additional recording time:** Up to 10 minutes per megabyte of memory space available on the card.
- b. **Web Updates:** Be sure to check back at www.autometer.com for future upgrades and updates for your NEXUS system.
- c. **PC Download:** Transfer your SD card between your NEXUS remote and your computer to download information for graphical analysis to your optional N2.0 software. See *N2.0 software instructions for further details.*
- d. **Program Custom Initialization, Shutdown, and Demo Sequences:** Program your own initialization, shutdown and demo sequences on your PC transfer them to your SD card and load them into your NEXUS system for the ultimate in personalized instrumentation. See Customizing NEXUS section.
- e. SD card size limited to 2 GB or lower. File system needs to be FAT 16.

Troubleshooting/FAQ:

The NEXUS system has a built in self-diagnostic system to help you troubleshoot operations problems. The system will indicate a problem or error by blinking the Malfunction Indicator Lamp (MIL) on the remote in a particular series to indicate the cause of the problem. Listed below is a table of codes and what they indicate.

Remote MIL Error Code	Cause for Error Code	Details
4 -1 Blink Code	Gauge communication Error	Zero gauges found on the Network (check connection between gauges and module). Note: Tachometers do not apply.
4 – 2 Blink Code	Module Communication Error	Module not found, contact Auto Meter Tech Support for Assistance.
5 – 2 Blink Code	Incorrect Pulse per Rev Switch Setting	Tachometer Pulse per rev switches are not in a supported setting.

Note: For all other error codes contact Auto Meter Tech Support for assistance.
service@autometer.com
815-899-0801

Customizing NEXUS:

Please check our website, email, or call for future updates and information on how to customize your NEXUS system.

www.autometer.com
sales@autometer.com
815-899-0800

NOTES:

NOTES:

NOTES:

SERVICE

For service send your product to Auto Meter in a well packed shipping carton. Please include a note explaining what the problem is along with your phone number. Please specify when you need the product back. If you need it back immediately mark the outside of the box "RUSH REPAIR," and Auto Meter will service product within two days after receiving it. (\$10.00 charge will be added to the cost of "RUSH REPAIR.") If you are sending product back for Warranty adjustment, you must include a copy (or original) of your sales receipt from the place of purchase.

12 MONTH LIMITED WARRANTY

Auto Meter Products, Inc. warrants to the consumer that all Auto Meter High Performance products will be free from defects in material and workmanship for a period of twelve (12) months from date of the original purchase. Products that fail within this 12 month warranty period will be repaired or replaced at Auto Meter's option to the consumer, when it is determined by Auto Meter Products, Inc. that the product failed due to defects in material or workmanship. This warranty is limited to the repair or replacement of parts in the Auto Meter instruments. In no event shall this warranty exceed the original purchase price of the Auto Meter instruments nor shall Auto Meter Products, Inc. be responsible for special, incidental or consequential damages or costs incurred due to the failure of this product. Warranty claims to Auto Meter must be transportation prepaid and accompanied with dated proof of purchase. This warranty applies only to the original purchaser of product and is non-transferable. All implied warranties shall be limited in duration to the said 12 month warranty period. Breaking the instrument seal, improper use or installation, accident, water damage, abuse, unauthorized repairs or alterations voids this warranty. Auto Meter Products, Inc. disclaims any liability for consequential damages due to breach of any written or implied warranty on all products manufactured by Auto Meter.

FOR SERVICE SEND TO: AUTO METER PRODUCTS, INC.
413 W. Elm St., Sycamore, IL 60178 USA (815) 899-0801
Email us at service@autometer.com
<http://www.autometer.com>